

Bevel®

TRIM INSTALLATION

Downlight / Adjustable / Wall Wash

CAUTION READ BEFORE INSTALLATION:

- Power must be off before installing fixture.
- Lamps are extremely hot and will cause severe burns.
- Never touch lamp after ignition. Allow to cool first

USAI uses multiple methods to captivate trims into housings. See below to identify trim type

DOWNLIGHT / ADJUSTABLE / WALL WASH

FLANGED TRIM INSTALLATION:

TORSION SPRING STYLE TRIMS

TO INSTALL:

Install trim assembly by squeezing the two torsion springs together upward into aperture opening. Trim flange should be flush to ceiling when properly installed. Minimum 5/8" ceiling thickness is required to load springs forcing trim flange against ceiling flush.

NOTE: Consult factory for ceilings thicker than 1-1/4".

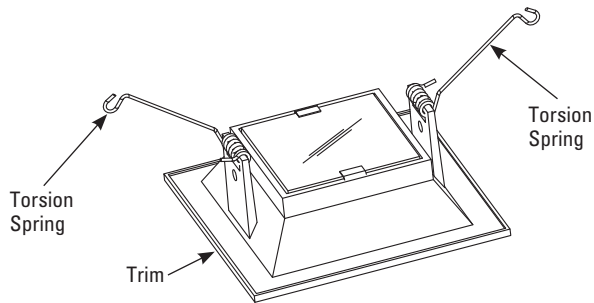

CLAW SPRING STYLE TRIMS

TO INSTALL:

Install trim assembly by pushing the two claw springs upward until trim edge sits flush inside collar. Maximum ceiling thickness of 1-1/4" is allowed for claw springs to remain engaged to hold trim securely.

NOTE: Consult factory for ceilings thicker than 1-1/4".

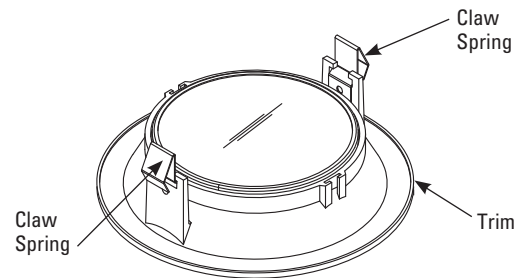

FLANGELESS TRIM INSTALLATION:

BALL PLUNGER STYLE TRIMS

TO INSTALL:

Install trim assembly by pushing the ball plunger springs upward into spackle frame until trim rests at the bottom of spackle frame.

NOTE: Any residue from joint compound or paint may prevent trim from sitting flush.

TO REMOVE:

To remove trim, raise glass upward, high enough to insert fingers to pull the edge of trim downward.

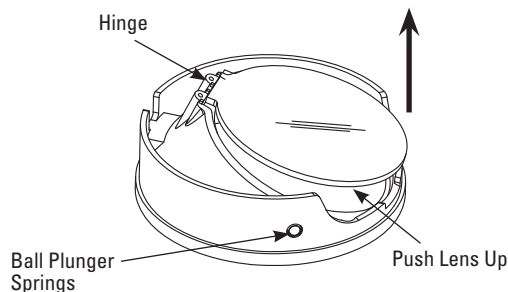

CLAW SPRING STYLE TRIMS

TO INSTALL:

Install trim assembly by pushing the claw springs upward into spackle frame until trim rests at the bottom of spackle frame.

NOTE: Any residue from joint compound or paint may prevent trim from sitting flush.

TO REMOVE: To remove trim, raise glass upward, high enough to insert fingers to pull the edge of trim downward.

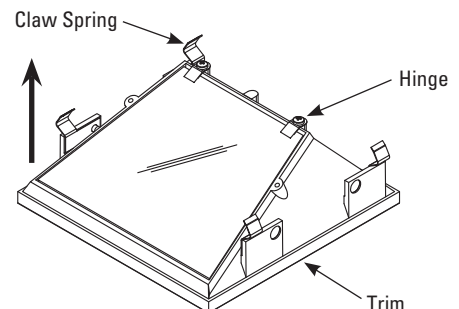

USAI®

www.usalighting.com
info@usalighting.com

1126 River Road
New Windsor, NY 12553

T 845-565-8500
F 845-561-1130

©2010. USAI, LLC.
All rights reserved.
All designs protected by copyright.
12-049