

BeveLED®

HOUSING INSTALLATION

Adjustable / Wall Wash

Accessible / Non-Accessible Ceilings

CAUTION READ BEFORE INSTALLATION:

- Power must be off before installing fixture.
- Fixtures must be installed in applications where the ambient temperature does not exceed 40°C during normal operation.
- **DO NOT** install fixtures in high humidity environments.
- **DO NOT** connect or disconnect LED board wire connector when fixture is energized, as this may result in permanent damage to the LED array.

Installation for BeveLED housings:

BeveLED Round: LRTA4-8310-C1 - Adjustable 30°, 10W LED
Ceiling Cutout 5"Ø LRTA4-8320-C1 - Adjustable 30°, 20W LED
 LRTA4-8410-C1 - Adjustable 40°, 10W LED
 LRTA4-8420-C1 - Adjustable 40°, 20W LED
 LRTW4-6010-C1 - Wall Wash, 10W LED
 LRTW4-6020-C1 - Wall Wash, 20W LED

BeveLED Square: LSTA4-8310-C1 - Adjustable 30°, 10W LED
Ceiling Cutout 5" x 5" LSTA4-8320-C1 - Adjustable 30°, 20W LED
 LSTA4-8410-C1 - Adjustable 40°, 10W LED
 LSTA4-8420-C1 - Adjustable 40°, 20W LED
 LSTW4-6010-C1 - Wall Wash, 10W LED
 LSTW4-6020-C1 - Wall Wash, 20W LED

HOUSING INSTALLATION:

1. Mount fixture housing according to ceiling type.
 - C-channels (optional) are available for lay-in tile installations.
 - Nailer bars are supplied for sheetrock installations. To install nailer bars, slide bars thru slots in butterfly brackets and lock in place with 8-32 screw.

*See **IMPORTANT** note below

2. Install power cable conduit to J-box.
3. Make power supply connections in housing J-box compartment and re-install J-box cover.

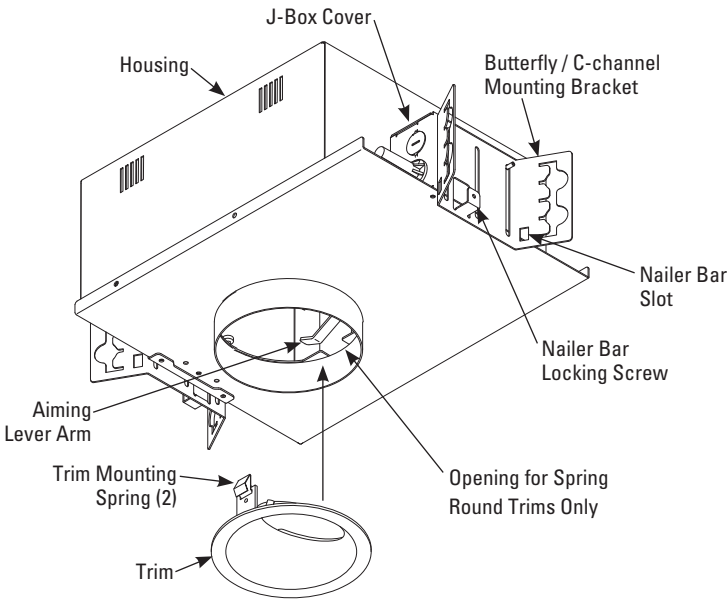

*IMPORTANT: DURING INSTALLATION APERTURE COLLAR MUST SET FLUSH TO CEILING

- NOTE:**
- Butterfly brackets are fixed at factory to allow aperture collar to sit flush in 5/8" gypsum board ceiling.
 - Butterfly brackets must be reset and adjusted for lay-in type and gypsum board ceilings thicker than 5/8".

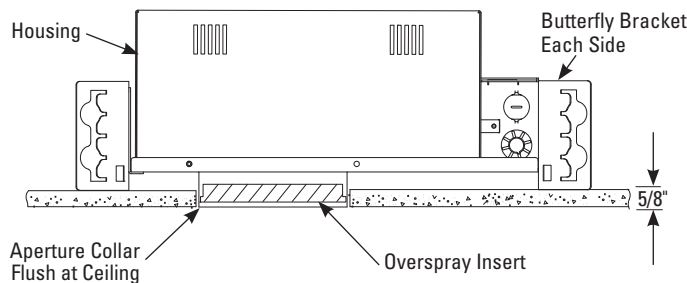

ALL-WAYS SQUARE APERTURE COLLAR ADJUSTMENT:

NOTE:

- All-Ways Square housings (square trims only) allow job site aperture plate adjustment after housings have been installed insuring parallel trim installations.
- Aperture is factory set to 0° rotation.
- Rotational alignment of the aperture plate must be completed prior to ceiling installation.

STEPS TO ADJUST THE APERTURE:

Note that the aperture plate is supplied with center line notches to aid in the alignment.

2. Remove the red locking screw and loosen the (4) aperture adjustment screws.
3. Rotate the aperture plate to the desired position and tighten the (4) aperture screws.
4. Discard red locking screw.

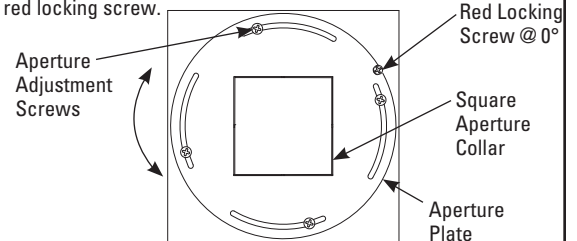

AIMING AND LOCKING:

1. **HORIZONTAL AIMING:**
Rotate adjustment carriage within 360°. Use thumb screw to lock.
2. **VERTICAL AIMING:**
Use aiming lever arm to adjust to a max of 40° tilt. Use thumb screw to lock.
3. **LENS HOLDER:**
Pull downward to remove.
2 Lens Media maximum.

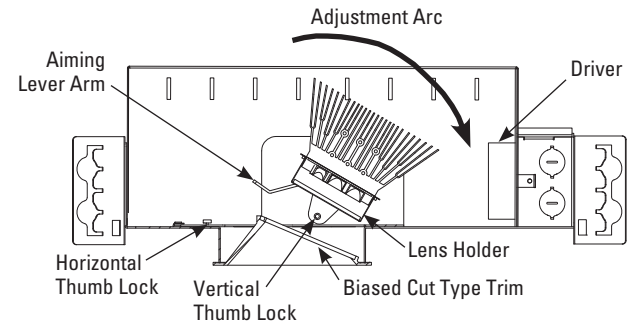

Fixture Shown: 3240-10-LRTA4-8410-C1-27-10-NC

BeveLED®

HOUSING INSTALLATION

Adjustable / Wall Wash

Accessible / Non-Accessible Ceilings

CAUTION READ BEFORE INSTALLATION:

- Power must be off before installing fixture.
- Fixtures must be installed in applications where the ambient temperature does not exceed 40°C during normal operation.
- DO NOT install fixtures in high humidity environments.
- DO NOT connect or disconnect LED board wire connector when fixture is energized, as this may result in permanent damage to the LED array.

TRIM INSTALLATION:

1. It is recommended that when ceiling installation is completed including all sanding and painting, the overspray protective insert can be removed.
2. Install trim assembly by pushing the two torsion springs upward into collar. Trim flange should be flush with ceiling when properly installed.

NOTE: Biased cut round fixtures will have cutouts in aperture plate allowing trim springs to protrude into plate. Trim angled cut must face LED source and adjustment arc.

NOTE: Biased cut square fixtures will have cutouts in aperture plate allowing trim springs to protrude into plate but must be installed where angled cut is facing LED source and adjustment arc.

DIMMING DRIVER WIRING SCHEMES:

DIM 2 LED: 0-10V 3-Wire FL Dimming Driver Wiring

NOTE: Consult dimmer manufacturer for detailed information.

For use with 0-10V 3-wire fluorescent type controls.

Use only with approved vendor models:

Lutron: DIVA DDTV-XX XX=Color

Leviton: IP710-DLX

Lightolier: V2000FAMU

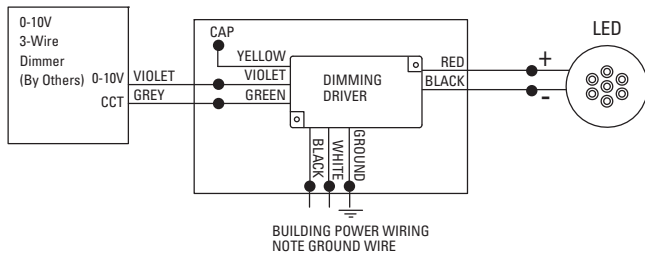

DIM 3 LED: HI-Lume/Lutron LED Dimming Driver Wiring

Consult dimmer manufacturer for detailed information

Wire Diagram for 2-Wire Control

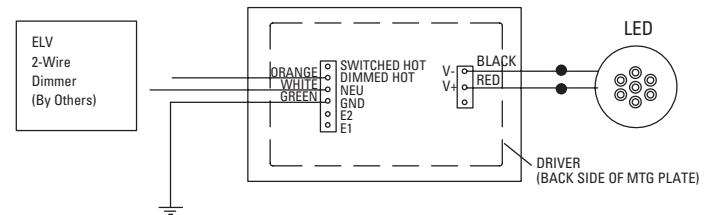

DIM 4 LED: HI-Lume/Lutron Eco-Sys A-Series LED Dimming Driver Wiring

Consult dimmer manufacturer for detailed information

Wire Diagram for 3-Wire Control

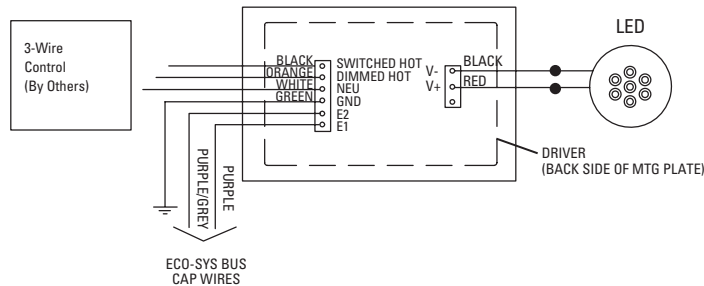

Wire Diagram for ECO-SYS Digital Control

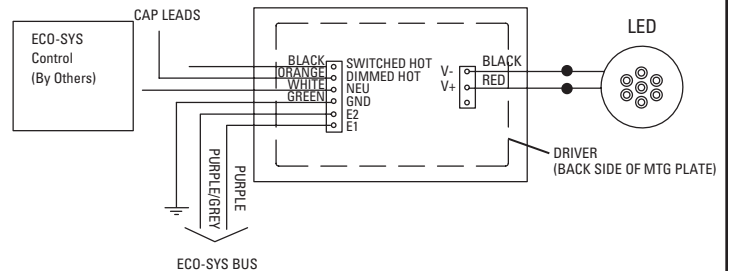

BeveLED®

Downlight

Light Engine Replacement Instructions

CAUTION READ BEFORE INSTALLATION:

- Power must be off before replacing light engine.

BeveLED light engine replacement in downlight C1 series:

SQUARE:	Trim	Trimless	ROUND:	Trim	Trimless
Downlight (10W)	LSTD4-9010-C1	LSTD4-9010-C1	Downlight (10W)	LRTD4-9010-C1	LRLD4-9010-C1
(20W)	LSTD4-9020-C1	LRTD4-9020-C1	(20W)	LRTD4-9020-C1	LRLD4-9020-C1

TO REMOVE LIGHT ENGINE:

1. With trim removed, carefully pull down and remove reflector.
2. Unfasten reflector ring screws (2) and conduit bracket screws (1) and remove reflector ring and conduit bracket.
3. Next disconnect LED power connector and let hang.

LED BOARD POWER DISCONNECT INSTRUCTIONS:

Depress small tab on LED power connector board port. While tab is depressed - pull to release.

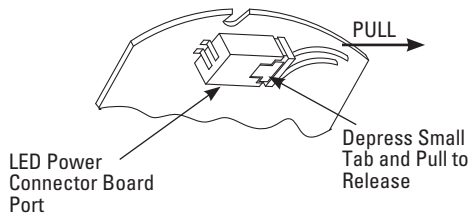

4. Remove 4-40 screws (2) securing light engine and carefully remove from heat sink. **DO NOT PULL ON LENS.**

TO RE-INSTALL LIGHT ENGINE:

1. Apply thermal compound (supplied) to bottom side of light engine board.

IMPORTANT

Light Engines must have a thermal compound applied to back side of LED light engine printed circuit board.

DO NOT INSTALL WITHOUT THERMAL COMPOUND.

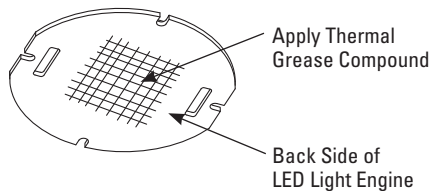

2. Replace light engine securing with 4-40 screws.
3. Reconnect power.
4. Replace reflector ring and conduit bracket - securing with 3 conduit bracket screws.
5. Carefully replace reflector and then trim.

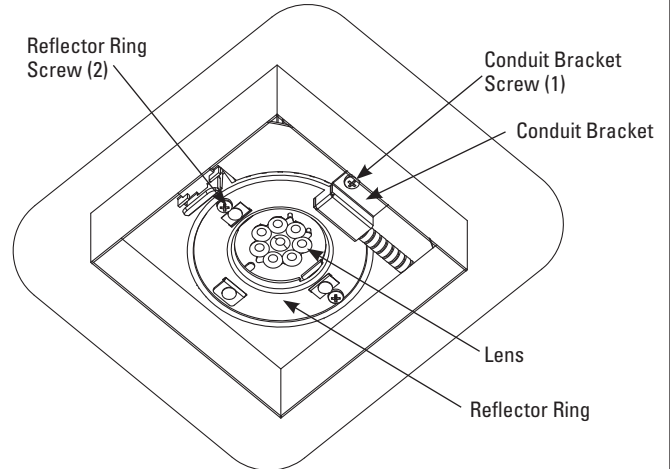

APERTURE COLLAR VIEW

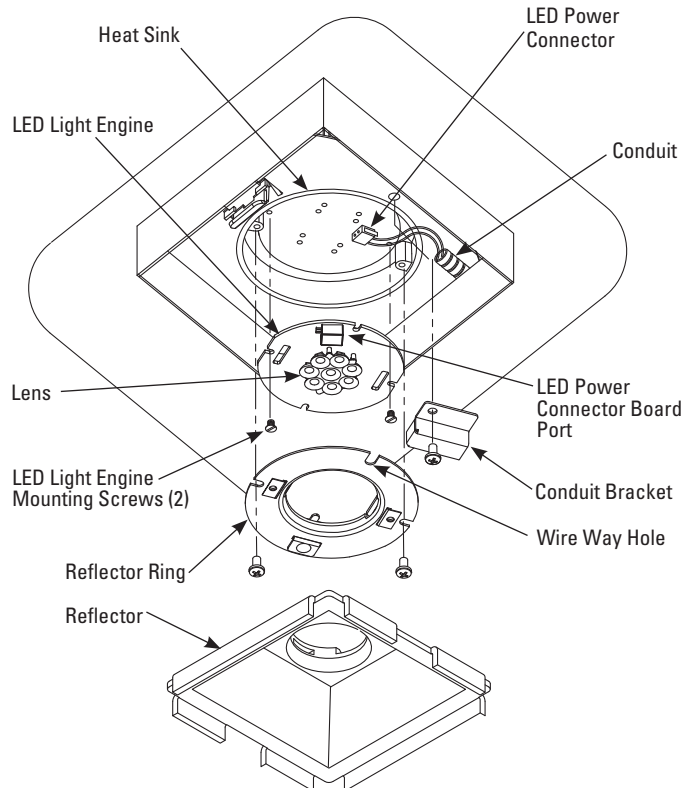

EXPLODED VIEW

BeveLED®

Adjustable 30° / Adjustable 40° / Wall Wash Light Engine Replacement Instructions

CAUTION READ BEFORE INSTALLATION:
• Power must be off before replacing light engine.

BeveLED light engine replacement in adjustable 30° / adjustable 40° / wall wash - C1 series:

SQUARE:		Trim	Trimless	ROUND:		Trim	Trimless
Adj. 30°	(10W)	LSTA4-8310-C1	LSLA4-8320-C1	Adj. 30°	(10W)	LRTA4-8310-C1	LRLA4-8310-C1
	(20W)	LSTA4-8320-C1	LSLA4-8320-C1		(20W)	LRTA4-8320-C1	LRLA4-8320-C1
Adj. 40°	(10W)	LSTA4-8410-C1	LSLA4-8410-C1	Adj. 40°	(10W)	LRTA4-8410-C1	LRLA4-8420-C1
	(20W)	LSTA4-8420-C1	LSLA4-8420-C1		(20W)	LRTA4-8420-C1	LRLA4-8420-C1
Wall Wash	(10W)	LSTW4-6010-C1	LSLW4-6010-C1	Wall Wash (10W)		LRTW4-6010-C1	LRLW4-6010-C1
	(20W)	LSTW4-6020-C1	LSLW4-6020-C1				LRTW4-6020-C1

TO REMOVE LIGHT ENGINE:

1. With trim removed, carefully pull out and remove glare shield.
2. Unfasten glare shield mounting ring screws (2) and remove.
3. Next disconnect LED power connector and let hang.

LED BOARD POWER DISCONNECT INSTRUCTIONS:
Depress small tab on LED power connector board port. While tab is depressed - pull to release.

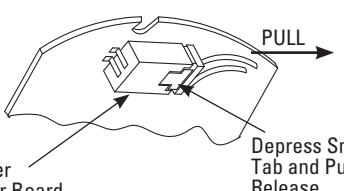

LED Power Connector Board Port

Depress Small Tab and Pull to Release

PULL

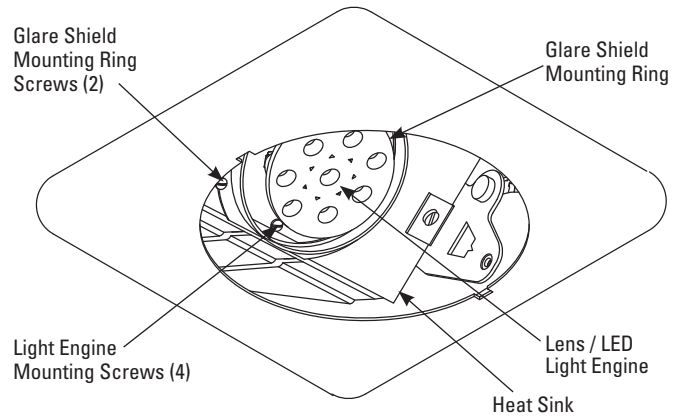

APERTURE COLLAR VIEW
(Shown Without Glare Shield)

4. Remove 4-40 screws securing light engine and carefully remove from heat sink. **DO NOT PULL ON LENS.**

TO RE-INSTALL LIGHT ENGINE:

1. Apply thermal compound (supplied) to bottom side of light engine board.

IMPORTANT
Light Engines must have a thermal grease compound applied to back side of LED light engine printed circuit board.
DO NOT INSTALL WITHOUT THERMAL COMPOUND.

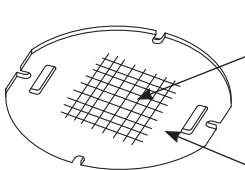

Apply Thermal Grease Compound

Back Side of LED Light Engine

2. Replace light engine securing with 4-40 screws.
3. Reconnect power.
4. Replace glare shield mounting ring - securing with 2 screws.
5. Replace trim.

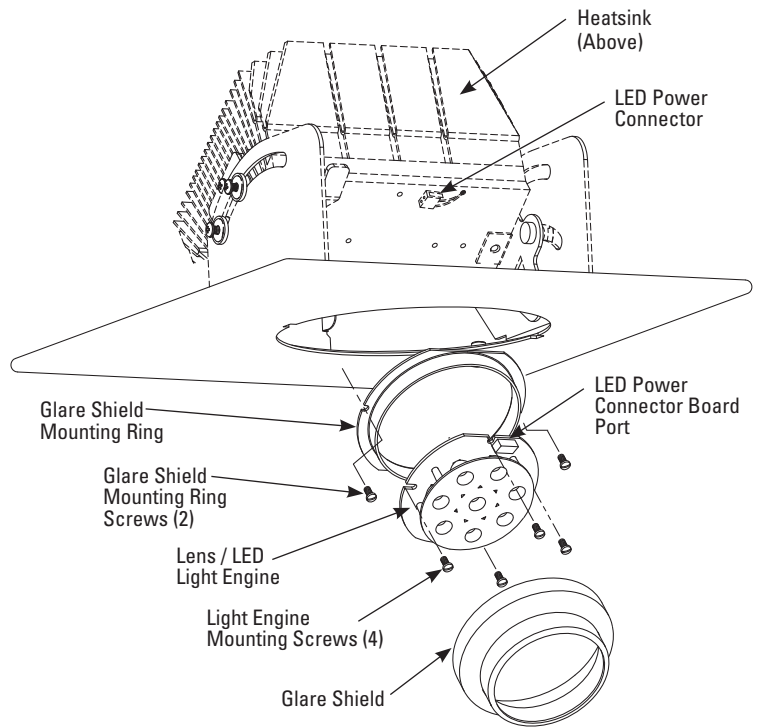

EXPLODED VIEW